

FULL PALLET TRANSFER CONVEYOR CAR

FP 3011

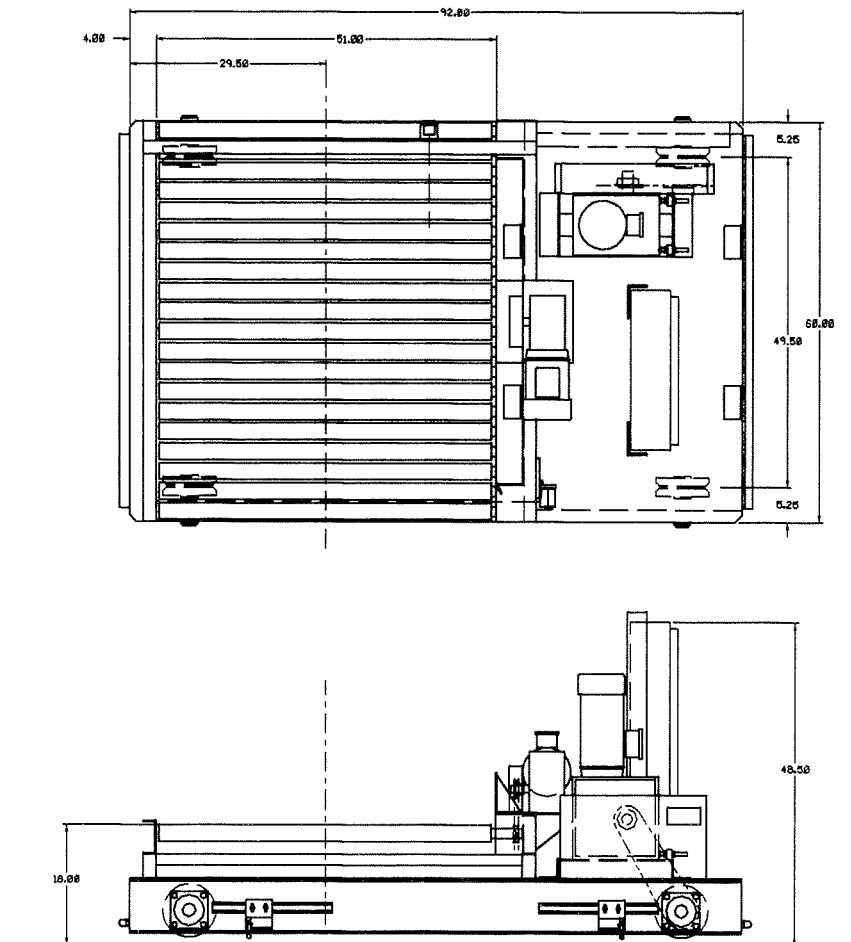

STANDARD SPECIFICATIONS

- Stand alone unit
- Rugged framework construction
- Operates on 8" steel wheels either on track buried in the floor or inverted angle on the floor
- Handles palletized or unitized loads 48" x 40" with weights up to 4,000 pounds
- Transporting conveyor can be chain driven live roller, wire mesh or chain conveyor
- Travel speeds up to 45 FPM
- Power requirements are 480VAC, 3PH, 60HZ, 15 amps service
- Controls and control cabinet are NEMA 12