

## BAG FLATTENER

BC 2000

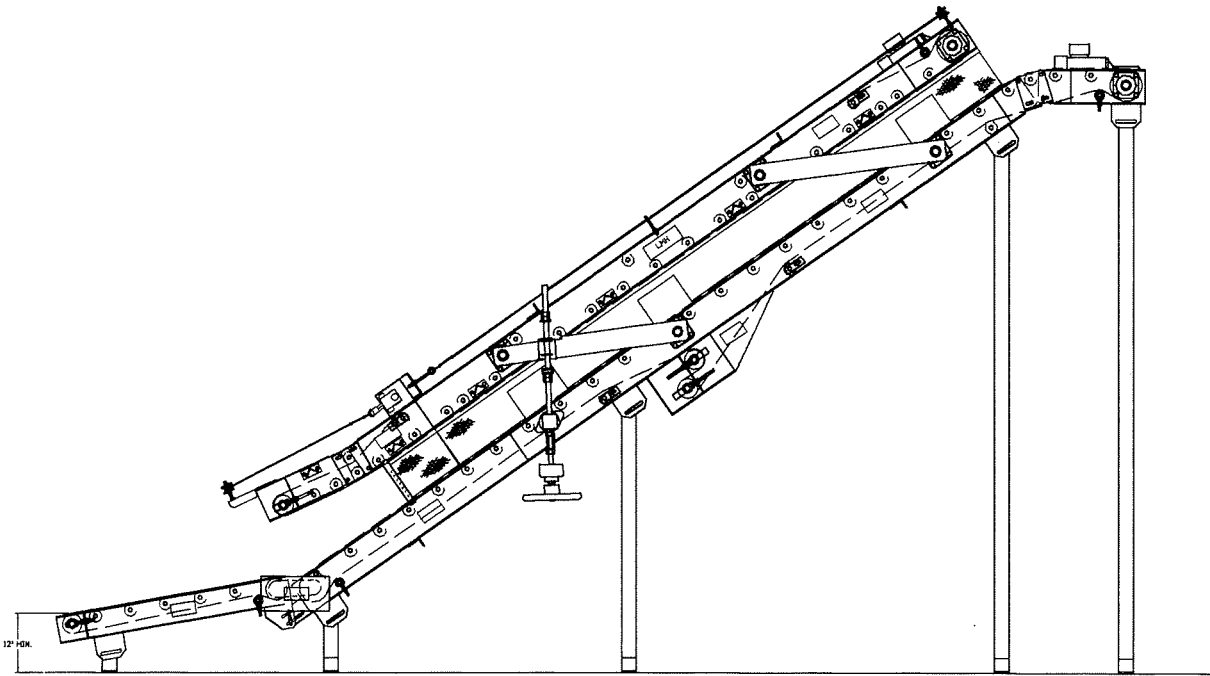

### STANDARD SPECIFICATIONS

- Std. Widths – (BF) 21", 24", 28"
- Std. Length – 18<sup>1</sup>/<sub>2</sub> ft. to 20<sup>3</sup>/<sub>4</sub> ft. depending on angle
- Angle of Incline – 15° to 35°
- Elevation
- Min. Infeed – 12"
- Min. Height – 52<sup>1</sup>/<sub>2</sub>" at 15° to top of flattener
- Max. Height – 111" at 35° to top of flattener
- Opening – 2" to 9"
- Frame – 7" side frame 7 gage with 1<sup>1</sup>/<sub>2</sub>" flange top & bottom
- Belt – 3 ply, 18", 21", 25" wide rough-top
- Speeds – 77, 102, 123 FPM both belts
- Motor – 3/4, 1, 1-1/2 HP C-face with shaft mounted reducer 230-460V, 3 PH, 60HZ
- Floor Supports – 3" x 4.1 lbs/ft. channel
- Capacity – 150 lbs/ft.
- Pulleys
  - Drive – 6"
  - Idler – 4" or 6"
  - Snub – 2"
- Power feeder belt standard
- Rollers under belt 2<sup>1</sup>/<sub>2</sub>" Dia on 8" centers
- Expanded metal guard between top & bottom conveyor
- Emergency safety cable and switch mounted to top conveyor
- Manually adjustable tension and height adjusting screw
- Paint – One coat Lambert blue